



Power Take-Offs Owner's Manual

238D Series



WARNING – User Responsibility

FAILURE OR IMPROPER SELECTION OR IMPROPER USE OF THE PRODUCTS DESCRIBED HEREIN OR RELATED ITEMS CAN CAUSE DEATH, PERSONAL INJURY AND PROPERTY DAMAGE.

This document and other information from Parker Hannifin Corporation, its subsidiaries and authorized distributors provide product or system options for further investigation by users having technical expertise.

The user, through its own analysis and testing, is solely responsible for making the final selection of the system and components and assuring that all performance, endurance, maintenance, safety and warning requirements of the application are met. The user must analyze all aspects of the application, follow applicable industry standards, and follow the information concerning the product in the current product catalog and in any other materials provided from Parker or its subsidiaries or authorized distributors.

To the extent that Parker or its subsidiaries or authorized distributors provide component or system options based upon data or specifications provided by the user, the user is responsible for determining that such data and specifications are suitable and sufficient for all applications and reasonably foreseeable uses of the components or systems.

Offer of Sale

The items described in this document are hereby offered for sale by Parker Hannifin Corporation, its subsidiaries or its authorized distributors. This offer and its acceptance are governed by the provisions stated in the "Offer of Sale".



WARNING: This product can expose you to chemicals including Lead and Lead Compounds, and Di (2-ethylhexyl) phthalate (DEHP) which are known to the State of California to cause cancer and birth defects or other reproductive harm. For more information go to www.P65Warnings.ca.gov

© Copyright 2025, Parker Hannifin Corporation, All Rights Reserved

Table of Contents

General Information

Foreword..... 1
Safety Information..... 1-5
PTO Safety Label Installation Instructions..... 5
Pump Bracketing Best Practices 6-7
Function of Auxiliary Power Shafts 8
Spicer® Universal Joint Engineering Data 9
PTO Shifting Procedure & Precautions..... 10
PTO Maintenance..... 11

General Installation

Mounting the PTO – 238D Series 12-15

Installation Sketches

Detroit® DT12® Shift Option V 16

Offer of Sale 17-19

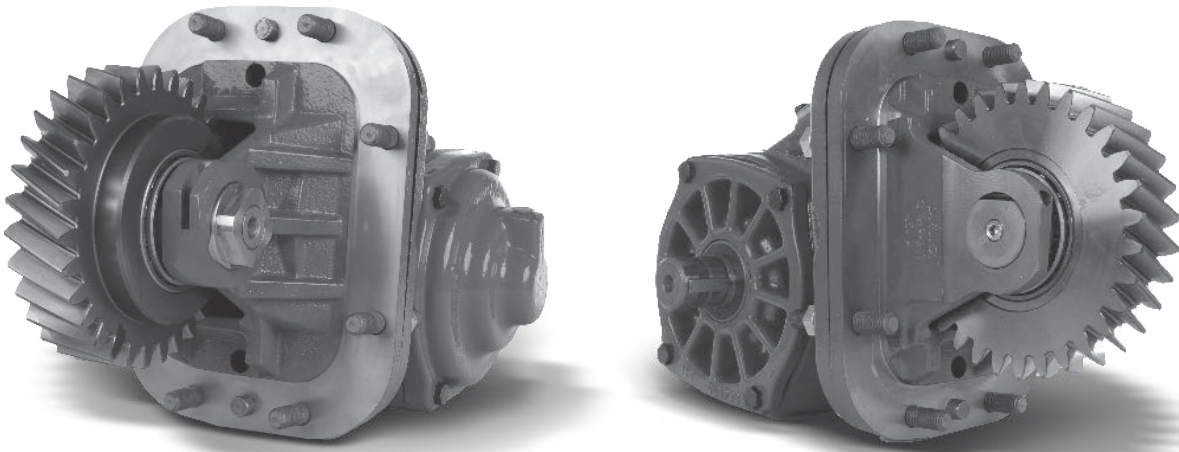

DAIMLER

General Information

Foreword

This booklet will provide you with information on correct installation of Chelsea® Power Take-Offs (PTOs). Proper installation and setup procedures can help you get additional and more profitable hours from your truck equipment and components.

It is important that you be sure that you are getting the right transmission and PTO combination when you order a new truck. A mismatched transmission and PTO combination can result in unsatisfactory performance of your auxiliary power system from the start.

If you have questions regarding correct PTO and transmission combination, please contact your local Chelsea® representative. They can help you select the properly matched components to ensure correct and efficient applications.

Safety Information

These instructions are intended for the safety of the system designer, installer, operator, and supporting personnel. If you have any additional questions after reading the instructions below, please reach out to your local Chelsea representative.

General Safety Information

To prevent injury to yourself and/or damage to the equipment:

- Carefully read all owner's manuals, service manuals, and/or other instructions.
- Always follow procedures using proper tools and safety equipment.
- Ensure proper training is received prior to attempting to install equipment.
- Always block any raised or moving device that may injure a person working on or under a vehicle.
- Never work alone while under a vehicle, repairing equipment, or maintaining equipment.
- Always use proper components in applications for which they are approved.
- Never use worn-out or damaged components.
- Never operate the controls of the PTO or other driven equipment from any position that could result in getting caught in the moving machinery.

Proper Matching of PTO



WARNING: A Power Take-Off must be properly matched to the vehicle transmission and to the auxiliary equipment being powered. An improperly matched Power Take-Off could cause severe damage to the vehicle transmission, the auxiliary driveshaft, and/or to the auxiliary equipment being powered. **Damaged components or equipment could malfunction causing serious personal injury to the vehicle operator or to others nearby.**

To avoid personal injury and/or equipment damage:

- Always refer to Chelsea's catalogs, literature, and owner's manuals.
- Follow Chelsea's recommendations when selecting, installing, repairing, or operating a PTO.
- Never attempt to use a PTO that is not specifically recommended by Chelsea for the vehicle, transmission, and application.
- Always match the PTO's specified output capabilities with the requirements of the equipment to be powered.
- Never exceed the maximum speed listed in Chelsea's Applications Catalog.
- Only use 329932X, 329954X & 329955X Adapter assemblies with Chelsea 489 and 238 Series Power Take-Offs. A keyed feature (see diagram below) is integrated into both the PTO and adapter flanges to ensure only these PTOs and adapters can be used together.



This symbol warns of possible personal injury.

General Information

Safety Information (Cont'd)

To avoid personal injury and/or equipment damage (Cont'd):

- Use of 329932X, 329954X & 329955X Adapter assemblies with any other Chelsea Power Take-Off series could cause severe damage to the vehicle transmission, transmission components or the Power Take-Off.
- The Power Take-Off warranty will be void if 329932X, 329954X & 329955X Adapter assemblies are used with any other Power Take-Offs other than Chelsea 489 and 238 Series Power Take-Offs. See diagram.

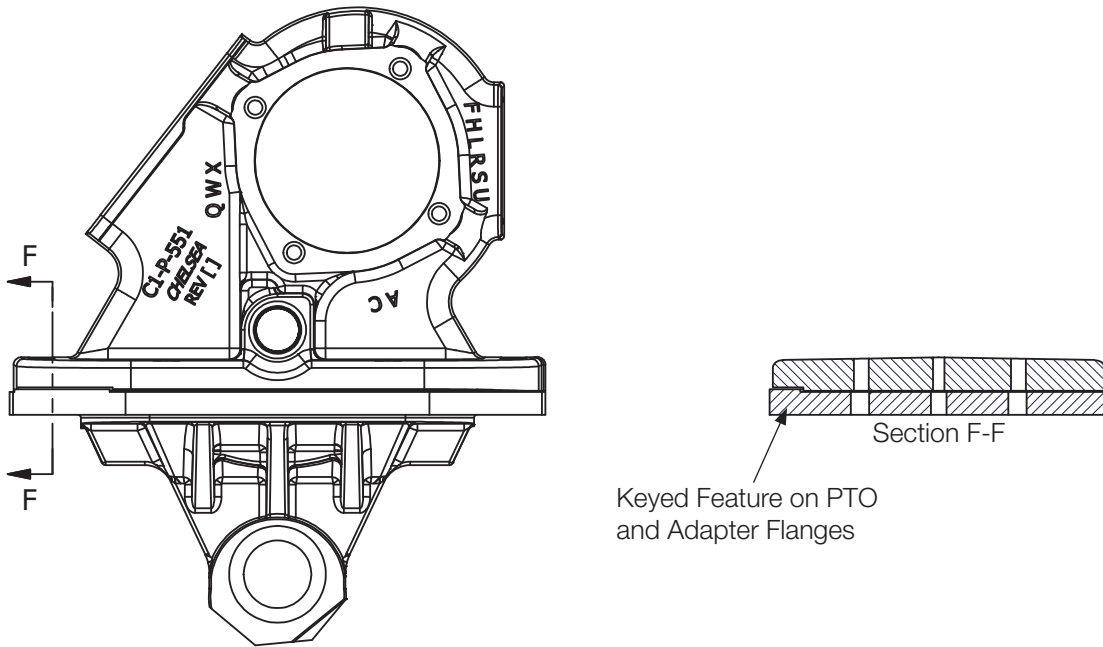

- Use of other Chelsea Power Take-Offs such as 680, 880 or 823 series with 329932X, 329954X and 329955X Adapter assemblies will result in a visible gap between the adapter and the Power Take-Off. This gap will be present because the PTO/adapter combination is incorrect. If the incorrect Power Take-Off and adapter combination is installed on the transmission, fluid leakage will occur during initial transmission fluid filling.

If a gap is present between the adapter and Power Take-Off during assembly or leakage occurs after initial fluid filling, remove the Power Take-Off and adapter immediately. Double check and ensure the correct Power Take-Off and Adapter assembly are being used for the application.

See directions and compatibility chart on the following page for correct Transmission/Adapter/PTO combinations.

General Information

Safety Information (Cont'd)

Compatibility Chart

CAUTION: The Detroit® DT12® transmission is offered in 3 model numbers for Power Take-Off (PTO) applications. It is critical that each transmission is matched with a specific adapter and compatible PTO input gear for correct system function. A compatibility chart is listed below so the installer can verify the correct adapter and PTO input gear are being used with the transmission.

Directions:

In the chart below find the transmission model and then reading left to right confirm the P/N of your adapter gear and the part number on the PTO input gear. Make sure the part number on the side of your adapter gear and the side of the PTO input gear match your Transmission Model **BEFORE INSTALLING** onto the transmission.

Failure to use compatible Adapter Assembly and PTO input gears with the correct transmission could result in personal injury, equipment damage, and voided warranty.

1 – IF THE MODEL NUMBER ON YOUR WHITE PTO TAG STARTS WITH 238 SERIES PTO		
2 – And your DT12® Transmission is:	3 – The Part No. stamped on your adapter gear must be:	4 – And the Part No. on your PTO input gear must be one of these:
OV/OHE G 320-12	43-P-170	5-P-1596/5-P-1709
DV/DHE G 271-12	43-P-171	5-P-1599
OVX G 340-12	43-P-172	5-P-1601/5-P-1711

Cold Weather Operation of PowerShift PTO

 **WARNING:** During extreme cold weather operation [32°F (0°C) and lower], a disengaged PowerShift Power Take-Off can momentarily transmit high torque that will cause unexpected output shaft rotation. This is caused by the high viscosity of the transmission oil when it is extremely cold. As slippage occurs between the Power Take-Off clutch plates, the oil will rapidly heat up, and the viscous drag will quickly decrease.

The rotation of the PTO's output shaft could cause unexpected movement of the driven equipment resulting in serious personal injury, death, or equipment damage.

To avoid personal injury or equipment damage:

- Driven equipment must have separate controls.
- The driven equipment must be left in the disengaged position when not in operation.
- Do not operate the driven equipment until the vehicle is allowed to warm up.

 This symbol warns of possible personal injury.

General Information

Safety Information (Cont'd)

Rotating Auxiliary Driveshafts



WARNING:

- Rotating auxiliary driveshafts can cause serious injury or death by snagging clothes, skin, hair, hands etc.
- Do not go under the vehicle when the engine is running.
- Do not work on or near an exposed shaft when the engine is running.
- Shut off the engine before working on the PTO or driven equipment.
- Exposed rotating driveshafts must be guarded.

Guarding Auxiliary Driveshafts



WARNING: We strongly recommend that a Power Take-Off and a directly mounted pump be used to eliminate the auxiliary driveshaft whenever possible. If an auxiliary driveshaft is used and remains exposed after installation, it is the responsibility of the vehicle designer to specify guard(s) and PTO installer to install guard(s).

Using Set Screws



WARNING: Auxiliary driveshafts may be installed with either recessed or protruding set screws. If you choose a square head set screw, you should be aware that it will protrude above the hub of the yoke and may be a point where clothes, skin, hair, hands etc., could be snagged. A socket head set screw, which may not protrude above the hub of the yoke, does not permit the same amount of torquing as does a square head set screw. Also, a square head set screw, if used with a lock wire, will prevent loosening of the screw caused by vibration. Regardless of the choice made with respect to a set screw, an exposed rotating auxiliary driveshaft must be guarded.

Important Safety Information and Owner's Manual



WARNING: Chelsea Power Take-Offs are packaged with warning labels, safety information decals, instructions, and an owner's manual. These items are located in the envelope with the PTO mounting gaskets. Also, safety information and installation instructions are packaged with some individual parts and kits. Be sure to read the owner's manual and safety information before installing or operating the PTO. Always install the safety information decals according to the instructions provided. Place the owner's manual in the vehicle glove compartment.



This symbol warns of possible personal injury.

General Information

Safety Information (Cont'd)

! WARNING: Operating the PTO with the Vehicle in Motion

Some Power Take-Offs may be operated when the vehicle is in motion. PTOs must be properly selected to operate at highway speeds, correctly matched to the vehicle's transmission, as well as the requirements of the driven equipment.

If in doubt about the PTO specifications and capabilities, avoid operating the PTO when the vehicle is in motion. Improper application and/or operation can cause serious personal injury as well as premature failure of the vehicle, driven equipment, and PTO.

Always remember to disengage the PTO when the driven equipment is not in operation.

PTO Safety Label Instructions

1. The two black and orange on white 5" x 7" pressure sensitive vinyl labels (PN 379274) must be placed one on each side of the vehicle in a position that would be **HIGHLY** visible to anyone that would go under the truck near the PTO rotating shaft. If the vehicle is to be painted after these labels are installed, cover them with two blank masking covers. Remove the masking covers after painting.
2. Place the one black and orange on white 3.5" x 5" pressure sensitive vinyl label (PN 379275) on the sun visor nearest the operator of the vehicle.
3. Place the one red and white with black lettering 3.5" x 7" pressure sensitive vinyl label (PN 379915) on the sun visor next to the above label (PN 379275).
4. Place the one white and black heavy-duty card (PN 379276) in the vehicle glove box in a position highly visible to the operator. For example, try to place this card on top of whatever may be in the glove box.

If you require labels, please order part number 328946X at no charge from your local Chelsea representative or send request direct to:

Parker-Hannifin Corporation
Chelsea Products Division
8225 Hacks Cross Road
Olive Branch, MS 38654

Phone: +1 (662) 895-1011
Email: chd_support@support.parker.com

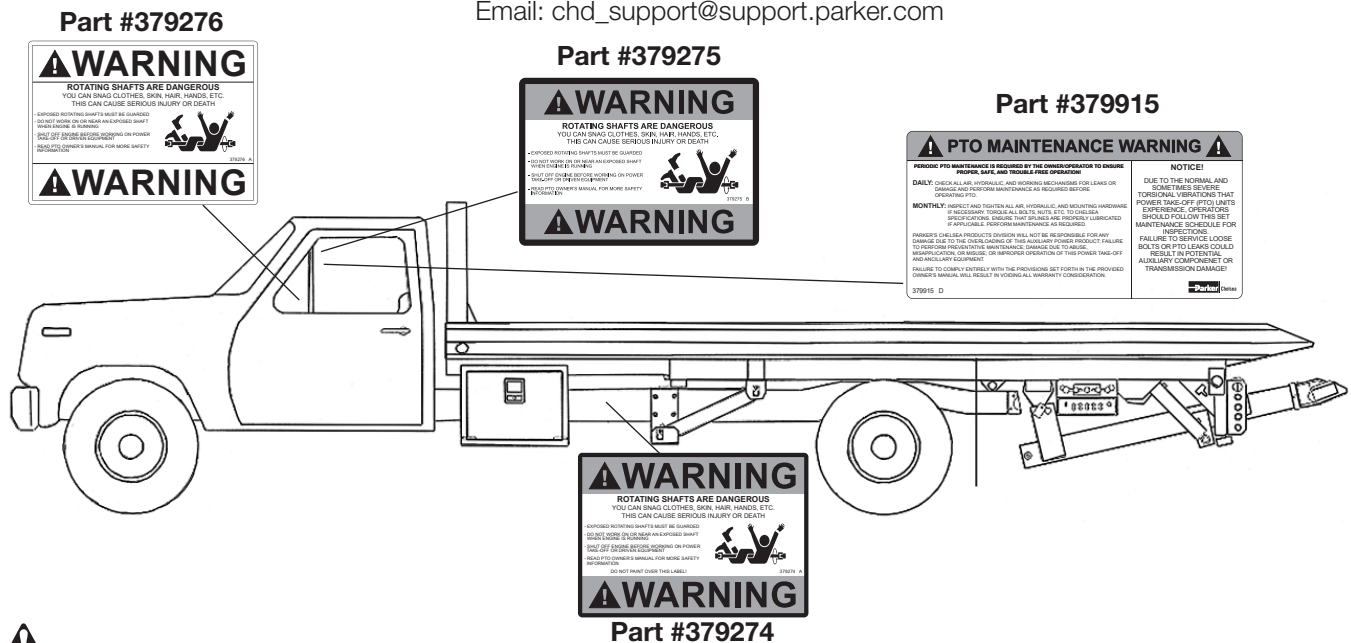

! This symbol warns of possible personal injury.

General Information

Pump Bracketing Best Practices

With changes in emissions standards, truck systems are experiencing more vibration and vibration related issues. Due to the changes, Parker Chelsea finds it necessary to discuss the importance of pump bracketing and the effects it can have on the mounted PTO. Parker Chelsea has made updates to the pump bracketing support guidelines listed in all PTO Owner's Manuals. This bulletin will discuss the importance of bracketing and the best practices to keep in mind when mounting a pump.

Please note, due to the high variance of applications and the increasing severity of vibration found in modern diesel engines Parker Chelsea's pump bracketing best practices cannot consider all factors affecting the PTO and Pump bracketing. Please use the following information as a GUIDELINE ONLY when installing pump bracketing.

Potential causes of bracket failures that can damage a PTO and/or Pump:

- Excessive preload from poor bracket design, fabrication, and installation.
- Excessive vibration from the vehicle's normal driving operation leading to high loads on the PTO bolts.
- Torque spikes from extreme vibration could be intense enough to break bolts in the bracketing. The worst cases occur while the truck is operating at highway speeds.

⚠ WARNING: In addition to the conditions listed above, Chelsea requires the use of support brackets in all applications to ensure the **Maximum Bending Moment (MBM)** of the PTO and pump assembly is not exceeded. Exceeding the MBM can result in damage to PTO, transmission, driven equipment, and/or personnel. It is the responsibility of the installer to ensure that adequate support is implemented. All applications are unique and it is important to consider all parameters in designing a proper support bracket.

Use **CAUTION** to ensure the support bracket does not pre-load PTO and pump mounting. Prior to mounting, pumps must be fully supported by a jack until it is properly secured with support bracket(s). This will ensure the PTO is not being stressed by the bracket. Brackets must be designed to adequately eliminate deflections from weight, vibration, and truck movements.

PTO warranty will be voided if support brackets are not used when one of the following conditions apply:

- Combined weight of the pump, fittings, hoses, and oil exceeds 40 lbs [18.14 kg]
- Combined length of the PTO and pump is greater than 18 inches [45.72 cm]
- Pumps should have a support bracket when mounted onto a on a non-extended shaft PTO
- Extended Shaft PTOs: Please see applicable owner's manual for additional guidance

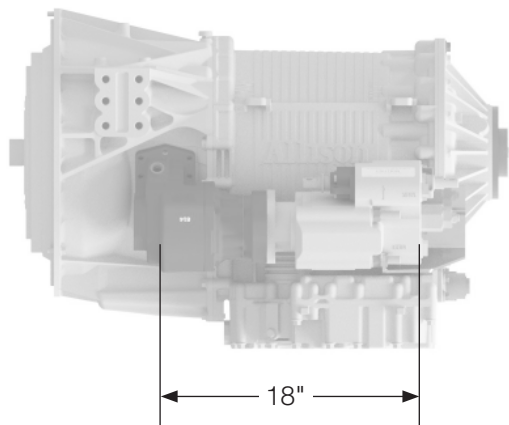

To ensure proper bracketing, brackets must attach at two or more transmission bolt locations as well as two or more pump (bolt) locations. Please reach out to your transmission manufacturer for proper bracket mounting locations.

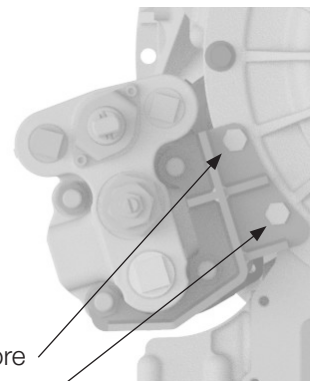

⚠ This symbol warns of possible personal injury.

General Information

Pump Bracketing Best Practices (Cont'd)

An installed PTO/Pump bracket needs to be properly aligned. Misalignment in the X direction (**Fig. 1**) is substantially more impactful than misalignment in the Y or Z direction (**Fig. 2**). To prevent this, installing a fixture-built bracket is preferred. This allows the PTO/Pump to be installed prior to making the final welds on the bracket.

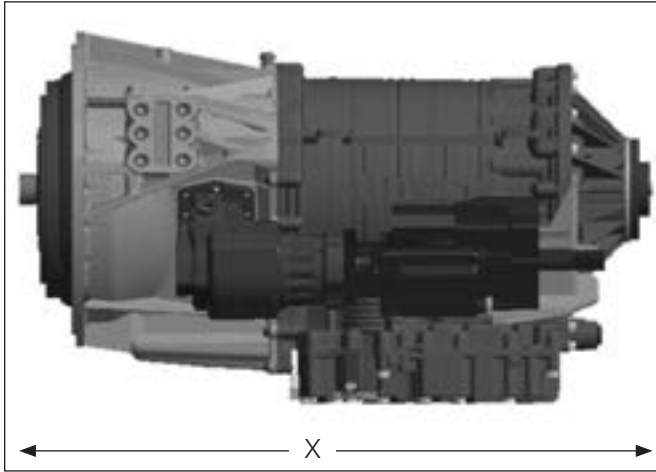

Figure 1

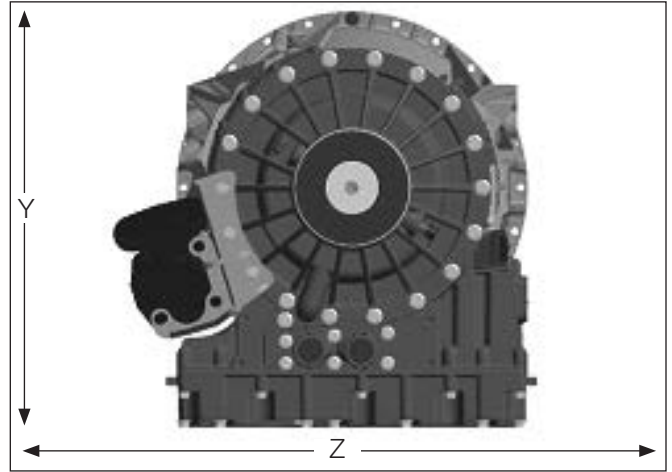
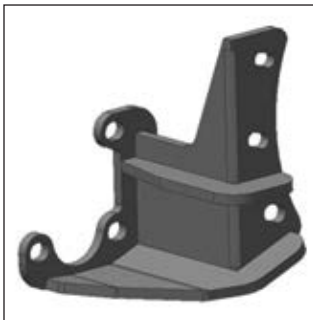

Figure 2

- The PTO/Pump should be treated as engine mounted components and installed per the engine manufacturer's published guidelines for engine mounted components when applicable.
- For proper bracketing, attach the bracket at two or more transmission bolt locations and two or more pump locations. Whenever possible, three attachment points in either (or both) locations is suggested. Please contact the transmission manufacturer for proper bracket mounting locations.
- Brackets should contain at least one gusset, preferably two. The gussets should be 3/8" thick and at least 1" deep. 3/8" steel is suggested particularly with gussets and in areas with reduced cross section.
- Please refer to the transmission and pump manufacturer's approved pump bracket support locations.



These best practices should be followed for optimal results. Please note, each bracketing situation is different so this bulletin must only be used as a guideline. For further bracketing assistance please refer to your PTO Owner's Manual or contact your Chelsea PTO representative for questions.

If you have any technical questions, contact us at:

Phone: +1 (662) 895-1011

Email: chd_support@support.parker.com

General Information

Function of Auxiliary Power Shafts

An auxiliary power shaft transmits torque from the power source to the driven accessory. The shaft must be capable of transmitting the maximum torque and RPM required of the accessory, plus any shock loads that develop.

An auxiliary power shaft operates through constantly relative angles between the power source and the driven accessory. Therefore, the length of the auxiliary power shaft must be capable of changing while transmitting torque. This length change, commonly called slip movement, is caused by movement of the power train due to torque reactions and chassis deflections.

Joint operating angles are very important in an auxiliary power joint application. In many cases, the longevity of a joint is dependent on the operating angles in the chart below.

SPICER® UNIVERSAL JOINT OPERATING ANGLES			
Prop. Shaft RPM	Max. Normal Operating Angle	Prop. Shaft RPM	Max. Normal Operating Angle
3000	5° 50'	1500	11° 30'
2500	7° 00'	1000	11° 30'
2000	8° 40'	500	11° 30'

The operating angles provided above are based on angular acceleration of 100 RAD/SEC².
NOTE: This information is limited to 1000 through 1310 series applications. Please contact your driveline specialist for applications requiring a series larger than 1310.

 **WARNING:** Direct customer to driveline manuf/spec.

Determining Shaft Type

- 1) Solid or tubular?
 - a) In applications requiring more than 1000 RPM or where the application necessitates a highly balanced auxiliary power shaft, a tubular shaft should be used.
 - b) Spicer's solid shaft auxiliary power joints are designed for intermittent service at 1000 or less RPM. Examples include driving of small hydraulic pumps, low speed product pumps, and winches.
- 2) Joint Series should be determined using the chart on the following page.

 This symbol warns of possible personal injury.

General Information

Spicer® Universal Joint Engineering Data

Joint Series	1000	1100	1280	1310
Torque Rating				
Automotive (Gas or Diesel Engine) lb-ft Continuous	50	54	95	130
Tubing				
Diameter	1.750"	1.250"	2.500"	3.000"
Wall Thickness	.065"	.095"	.083"	.083"
W = Welded S = Seamless	W	S	W	W
Flange Diameter (Swing Diameter)				
Rectangular Type	3.500"	3.500"	3.875"	3.875"
Bolt Holes - Flange Yoke				
Circle	2.750"	2.750"	3.125"	3.125"
Diameter	.312"	.312"	.375"	.375"
Number	4	4	4	4
Male Pilot Dia.	2.250"	2.250"	2.375"	2.375"
Distance Across Lugs				
Snap Ring	2.188"	2.656"	3.469"	3.469"
Construction	2.188"	2.656"	3.469"	3.469"
Bearing Diameter	.938"	.938"	1.062"	1.062"

^{1,2} Maximum Operating Speed for Tube or Solid Shaft Diameter and Length

Tube	RPM - Revolutions per Minute				
	500	1000	1500	2000	2500
OD x Wall Thickness (Joint Type)					
1.750" x .065" (Welded)	117"	82"	67"	58"	52"
1.250" x .095" (Seamless)	91"	64"	52"	45"	40"
2.500" x .083" (Welded)	122"	87"	70"	62"	55"
3.000" x .083" (Seamless)	-	-	-	85"	76"
Solid Shaft	RPM - Revolutions per Minute				
	500	1000	1500	2000	2500
Diameter					
.750"	60"	42"	35"	30"	27"
.812"	62"	44"	36"	31"	28"
.875"	65"	46"	37"	32"	29"
1.000"	69"	49"	40"	35"	31"
1.250"	77"	55"	45"	39"	35"

¹ The numbers expressed above represent the maximum installed length for tubing or solid shaft in both two joint assemblies and joint shaft applications.

² Please contact your Chelsea representative for applications with speeds below 500 RPM and over 2500 RPM.

 **WARNING:** direct customer to driveline manuf/spec.

 This symbol warns of possible personal injury.

PTO Shifting Procedure & Precautions

CAUTION: This vehicle is equipped with a Power Take-Off. Shut engine off before working on the Power Take-Off or getting below the vehicle. Consult the operating instructions before using the PTO (See sun visor).

POWER TAKE-OFF OPERATION — VEHICLE STATIONARY

Automatic Transmission with PowerShift PTO

Engage the PTO with the engine at idle speed.

NOTE: PowerShift PTO: The engine must be at idle or below 1000 RPM when the PTO is engaged. See the transmission manufacturer's instructions for special procedures.

IMPORTANT:

Failure to follow the proper shifting or operating sequences will result in premature PTO failure with possible damage to other equipment.



WARNING: Cold Weather Operation of PowerShift PTO

During extreme cold weather operation [32°F (0°C) and lower], a disengaged PowerShift Power Take-Off can momentarily transmit high torque that will cause unexpected output shaft rotation. This is caused by the high viscosity of the transmission oil when it is extremely cold. As slippage occurs between the Power Take-Off clutch plates, the oil will rapidly heat up and the viscous drag quickly decreases.

The rotation of the PTO's output shaft could cause unexpected movement of the driven equipment, resulting in serious personal injury, death, or equipment damage.

To avoid personal injury or equipment damage:

- Driven equipment must have separate controls.
- Driven equipment must be left in the disengaged position when not in operation.
- Driven equipment must not be operated until the vehicle is allowed to warm up.

General Information

Power Take-Off Maintenance

Due to the normal and sometime severe torsional vibrations that PTOs experience, operators should follow a set maintenance schedule for inspections. Failure to service loose bolts or PTO leaks could result in potential auxiliary Power Take-Off or transmission damage.

Periodic PTO maintenance is required by the owner/operator to ensure proper, safe, and trouble-free operation.

Daily: Check all air, hydraulic, and working mechanisms before operating PTO and perform maintenance as required.

Monthly: Inspect for possible leaks and tighten all air, hydraulic, and mounting hardware if necessary. Torque all bolts, nuts, etc., to Chelsea's specifications. If applicable, ensure that splines are properly lubricated. Perform maintenance as required.

With regards to the direct mounted pump splines, the PTO requires the application of a specially formulated anti-fretting grease. This grease must be specified for both high pressure and high temperature applications. The addition of the grease has been proven to reduce the effects of torsional vibrations, which result in fretting corrosion on the PTO's internal splines as well as the pump's external splines. Fretting corrosion appears as a rusting and wearing of the pump shaft splines. Severe duty applications, which require long PTO running times and high torque, may require more frequent regreasing. Continuous duty applications with light loads require frequent regreasing due to the higher number of running hours, an example of this is utility trucks. It is important to note that service intervals will vary for every application and they are the responsibility of the end user of the product. Chelsea also recommends that you consult your pump's owner's manual and technical services for their maintenance guidelines. Fretting corrosion is caused by many factors and without proper maintenance; the anti-fretting grease can only reduce its effects on components.

Chelsea offers anti-fretting grease to our customers in two package sizes:

- 5/8 fluid ounce tube (PN 379688) - Provided with PTO where applicable
- 14-ounce grease cartridge (PN 379831)

Warranty: Failure to comply entirely with the provisions set forth in the appropriate owner's manual will result in voiding of warranty consideration.

General Installation

Mounting the PTO 238D Series

1. Remove the PTO aperture cover plate (**Fig. 3**).
2. Discard the cover plate and cover plate gasket, then clean the aperture pad using a putty knife or wire brush (**Fig. 4**).

 **WARNING:** Ensure all fasteners and fittings are torqued according to their manufacturer's specification.

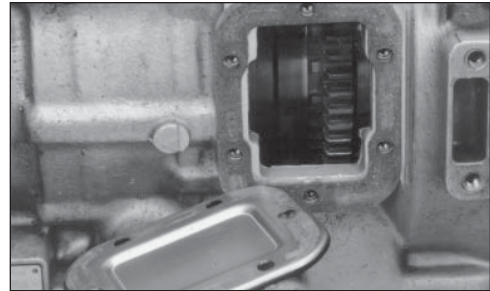

Figure 3

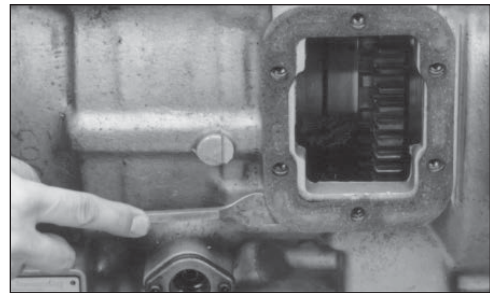

Figure 4

Detroit® DT12® PTO/Adapter Backlash Settings

1. On a workbench and starting with (1) thick gasket, bolt the adapter to the PTO with (8) M12-.438" hex head bolts, washers and nuts. Torque to 40-45 lb-ft [54-61 N-m] (**Fig. 5**).
2. With a dial indicator measure the backlash between the PTO gear and the adapter gear (**Fig. 6**).

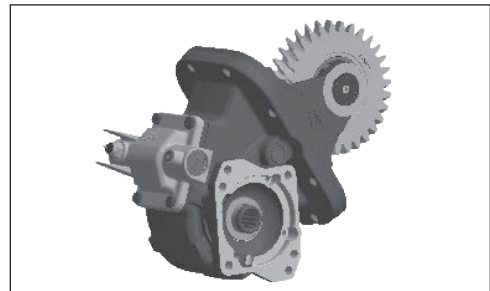

Figure 5



Figure 6

 This symbol warns of possible personal injury.

General Installation

Mounting the PTO (Cont'd)
238D Series

Detroit® DT12®
PTO/Adapter Backlash Settings (Cont'd)

3. Acceptable backlash measurement is .006"-.012" (0.15-0.30 mm) (**Fig. 7**).
4. If backlash is less than .006" (0.15 mm) then repeat assembly and add a thin gasket. If the backlash is more than .012" (0.30 mm) then replace the thick gasket with a thin gasket.
5. Disassemble adapter from PTO and retain gasket(s).

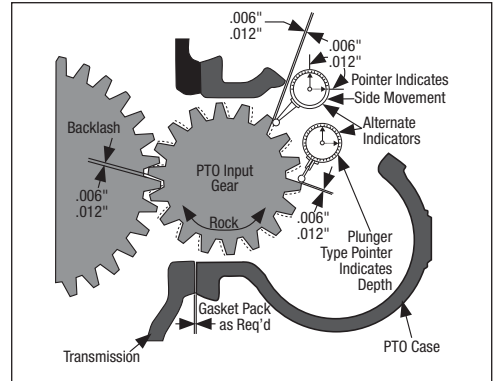

Figure 7

6. Install the proper studs (furnished with PTO) in the PTO aperture pad using a stud driver. Studs should be threaded into the transmission holes until the stud shank is even with transmission mounting surface. **DO NOT** install studs with shank below the aperture surface. Install studs with hand tools. **DO NOT** use power tools to install studs. (**Fig. 8**).

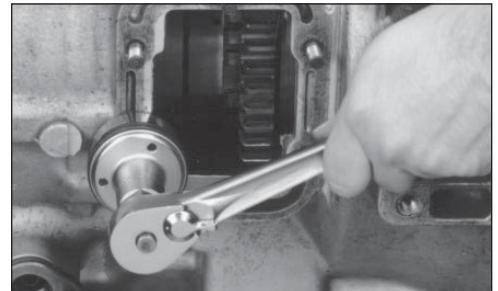

Figure 8

CAUTION: Over tightening of studs or running the shoulder past the transmission mounting surface may damage stud and/or transmission. Use of air impact tools is not recommended (**Fig. 9**).

7. Install dowel pins into transmission (some grease will help keep the pins in place).

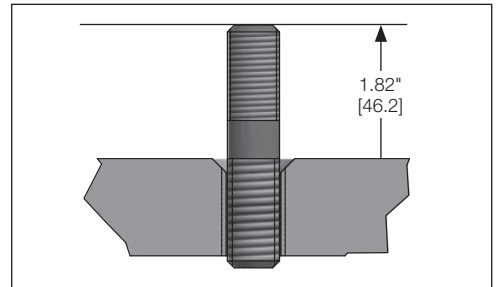

Figure 9

General Installation

Mounting the PTO (Cont'd) 238D Series

Detroit® DT12® Adapter Gasket Installation

1. Install adapter gasket over studs and dowel pins. Begin with (1) thick gasket (**Fig. 10**).

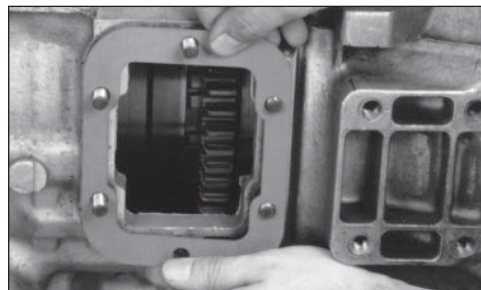

Figure 10

2. Offset to be towards the rear of the transmission (**Fig. 11**).

Gasket Thickness:

Thin Gasket = 0.010" (0.25 mm)

Thick Gasket = 0.020" (0.51 mm)

Self Locking Flange Nut 7/16"-20 Thread

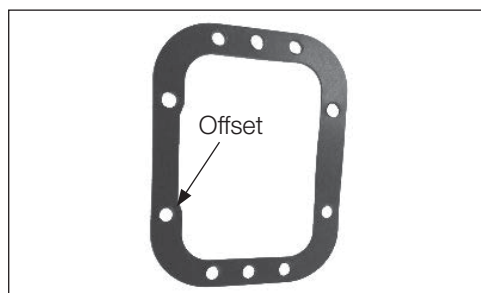

Figure 11

Detroit® DT12® Adapter Installation

1. Position adapter so ribs are towards the front of the transmission (**Fig. 12**).
2. Install adapter over studs and dowel pins. Rotate adapter gear to mesh with PTO drive gear in transmission.
3. Install locking nuts with washers to secure adapter in place. Washers are to protect the machined surface. Torque to 30-33 lb-ft [40-45 N-m].
4. With a dial indicator measure the backlash between the adapter gear and the PTO drive gear in transmission.
5. Acceptable backlash measurement is .006"-.012" (0.15-0.30 mm) (**Fig. 13**).

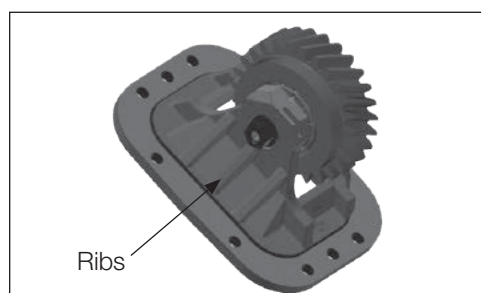

Figure 12

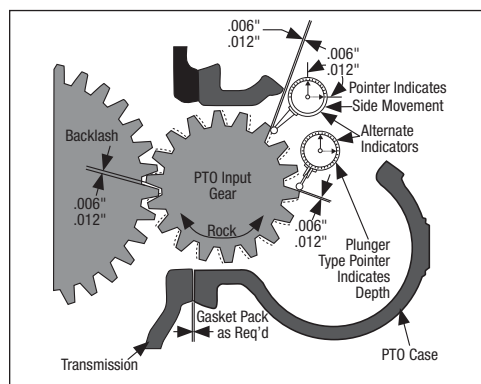

Figure 13

General Installation

Mounting the PTO (Cont'd) 238D Series

Detroit® DT12® Adapter Installation (Cont'd)

6. If backlash is less than .006" (0.15 mm) then add the thin gasket.
7. Remove locking nuts and washers. Install gasket(s) from PTO/adapter assembly over studs in transmission (step 5, page 13).
8. Support adapter with locking pliers so the adapter does not fall off the studs (be careful not to damage the threads).
9. Use the PTO inspection/shifter opening to gain access to the PTO internal gears.
10. Install PTO over studs and dowel pins.
11. Temporarily secure PTO with 2-3 locking nuts and remove locking pliers.
12. While rotating the input gear of the PTO, move the PTO into place until the PTO gear meshes with the adapter gear
13. Secure PTO to the transmission:
 - Use self-locking nuts provided with PTO (**Fig 14**).
14. Install all locking nuts and torque to 55-60 lb-ft [75-81 N-m] (**Fig 15 & 16**).

NOTE: Self-locking nuts do not require lock washers (**Fig. 16**).



Figure 14



Figure 15

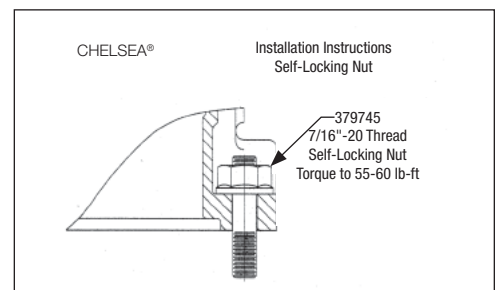

Figure 16



Detroit® DT12®
Shift Option V
238D Series

(SK-681 Rev B)

Installation Kit: 330114X

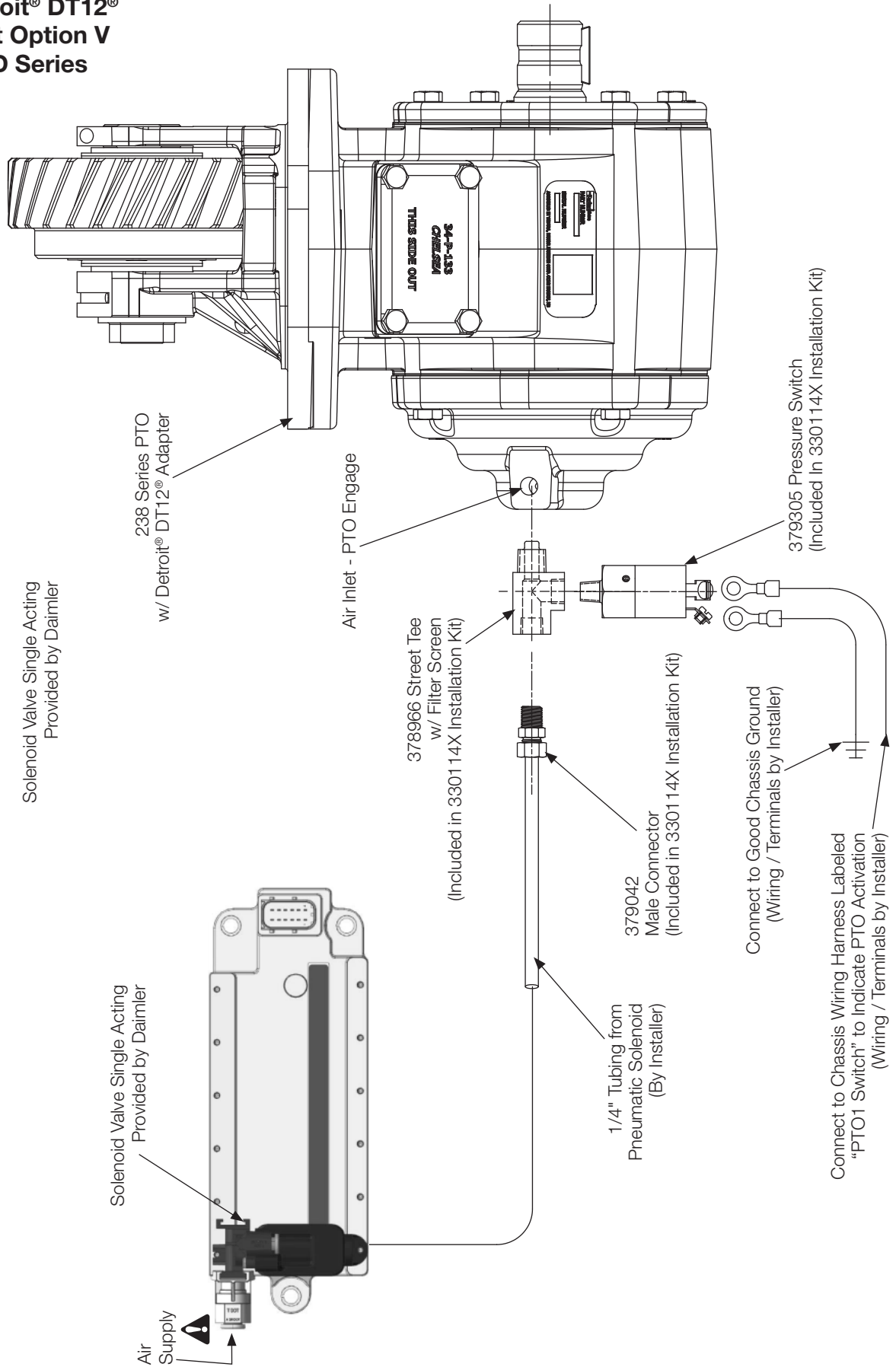

WARNING: Air supply connection to be factory installed by OEM.

Offer of Sale

WARNING: This product can expose you to chemicals including Lead and Lead Compounds, and Di(2-ethylhexyl)phthalate (DEHP) which are known to the State of California to cause cancer and birth defects or other reproductive harm. For more information go to www.P65Warnings.ca.gov

1. Definitions. As used herein, the following terms have the meanings indicated.

Buyer: means any customer receiving a Quote for Products.

Buyer's Property:

means any tools, patterns, plans, drawings, designs, specifications materials, equipment, or information furnished by Buyer, or which are or become Buyer's property.

Confidential Information:

means any technical, commercial, or other proprietary information of Seller, including, without limitation, pricing, technical drawings or prints and/or part lists, which has been or will be disclosed, delivered, or made available, whether directly or indirectly, to Buyer.

Goods:

means any tangible part, system or component to be supplied by Seller.

Intellectual Property Rights:

means any patents, trademarks, copyrights, trade dress, trade secrets or similar rights.

Products: means the Goods, Services and/or Software as described in a Quote.

Quote: means the offer or proposal made by Seller to Buyer for the supply of Products.

Seller: means Parker-Hannifin Corporation, all divisions, subsidiaries and businesses selling products under these terms.

Seller's IP: means patents, trademarks, copyrights, or other intellectual property rights relating to the Products, including without limitation, names, designs, images, drawings, models, software, templates, information, any improvements or creations or other intellectual property developed prior to or during the relationship contemplated herein.

Services: means any services to be provided by Seller.

Software: means any software related to the Goods, whether embedded or separately downloaded.

Special Tooling:

means equipment acquired by Seller or otherwise owned by Seller necessary to manufacture Goods, including but not limited to tools, jigs, and fixtures.

Terms: means the terms and conditions of this Offer of Sale.

2. Terms. All sales of Products by Seller will be governed by, and are expressly conditioned upon Buyer's assent to, these Terms. These Terms are incorporated into any Quote provided by Seller to Buyer. Buyer's order for any Products whether communicated to Seller verbally, in writing, by electronic data interface or other electronic commerce, shall constitute acceptance of these Terms. Seller objects to any contrary or additional terms or conditions of Buyer. Reference in Seller's order acknowledgement to Buyer's purchase order or purchase order number shall in no way constitute an acceptance of any of Buyer's terms or conditions of purchase. Any Quote made by Seller to Buyer shall be considered a firm and definite offer and shall not be deemed to be otherwise despite any language on the face of the Quote. Seller reserves all rights to accept or reject any purported acceptance by Buyer to Seller's Quote if such purported acceptance attempts to vary the terms of the Quote. If Seller ships Products after Buyer issues an acceptance to the Quote, any additional or different terms proposed by Buyer will not become part of the parties' business relationship unless agreed to in a writing that is signed by an authorized representative of Seller, excluding email correspondence. If the transaction proceeds without such agreement on the part of Seller, the business relationship will be

governed solely by these Terms and the specific terms in Seller's Quote.

3. Price; Payment. The Products set forth in the Quote are offered for sale at the prices indicated in the Quote. Unless otherwise specifically stated in the Quote, prices are valid for thirty (30) days and do not include any sales, use, or other taxes or duties. Seller reserves the right to modify prices for any reason and at any time by giving ten (10) days prior written notice. Unless otherwise specified by Seller, all prices are F.C.A. Seller's facility (INCOTERMS 2020). All sales are contingent upon credit approval and full payment for all purchases is due thirty (30) days from the date of invoice (or such date as may be specified in the Quote). Under any circumstances, Buyer may not withhold or suspend payment of any amounts due and payable as a deduction, set-off or recoupment of any amount, claim or dispute with Seller. Unpaid invoices beyond the specified payment date incur interest at the rate of 1.5% per month or the maximum allowable rate under applicable law. Seller reserves the right to require advance payment or provision of securities for first and subsequent deliveries if there is any doubt, in Seller's sole determination, regarding the Buyer's creditworthiness or for other business reasons. If the requested advance payment or securities are not provided to Seller's satisfaction, Seller reserves the right to suspend performance or reject the purchase order, in whole or in part, without prejudice to Seller's other rights or remedies, including the right to full compensation. Seller may revoke or shorten any payment periods previously granted in Seller's sole determination. The rights and remedies herein reserved to Seller are cumulative and in addition to any other or further rights and remedies available at law or in equity. No waiver by Seller of any breach by Buyer of any provision of these terms will constitute a waiver by Seller of any other breach of such provision.

4. Shipment; Delivery; Title and Risk of Loss. All delivery dates are approximate, and Seller is not responsible for damages or additional costs resulting from any delay. All deliveries are subject to our ability to procure materials from our suppliers. Regardless of the manner of shipment, delivery occurs and title and risk of loss or damage pass to Buyer, upon placement of the Products with the carrier at Seller's facility. Unless otherwise agreed prior to shipment and for domestic delivery locations only, Seller will select and arrange, at Buyer's sole expense, the carrier and means of delivery. When Seller selects and arranges the carrier and means of delivery, freight and insurance costs for shipment to the designated delivery location will be prepaid by Seller and added as a separate line item to the invoice. Buyer shall be responsible for any additional shipping charges incurred by Seller due to Buyer's acts or omissions. Buyer shall not return or repackage any Products without the prior written authorization from Seller, and any return shall be at the sole cost and expense of Buyer.

5. Warranty. The warranty for the Products is as follows:

(i) Seller warrants that all products sold conform to the applicable Parker Chelsea standard specification for the lesser period of 2 years (24 Months) from date of service or 2-1/2 years (30 Months) from date of build (as marked on the product name plate); (ii) Services shall be performed in accordance with generally accepted practices and using the degree of care and skill that is ordinarily exercised and customary in the field to which the Services pertain and are warranted for a period of six (6) months from the date of completion of the Services; and (iii) Software is only warranted to perform in accordance with applicable specifications provided by Seller to Buyer for ninety (90) days from the date of delivery or, when downloaded by a Buyer or end-user, from the date of the initial download. All prices are based upon the exclusive limited warranty stated above, and upon the following disclaimer:

EXEMPTION CLAUSE; DISCLAIMER OF WARRANTY, CONDITIONS, REPRESENTATIONS: THIS WARRANTY IS THE SOLE AND ENTIRE WARRANTY, CONDITION, AND REPRESENTATION, PERTAINING TO PRODUCTS. SELLER DISCLAIMS ALL OTHER WARRANTIES, CONDITIONS,

Continued on Next Page

Offer of Sale (Cont'd)

AND REPRESENTATIONS, WHETHER STATUTORY, EXPRESS OR IMPLIED, INCLUDING BUT NOT LIMITED TO THOSE RELATING TO DESIGN, NONINFRINGEMENT, MERCHANTABILITY, AND FITNESS FOR A PARTICULAR PURPOSE. SELLER DOES NOT WARRANT THAT THE SOFTWARE IS ERROR-FREE OR FAULT-TOLERANT, OR THAT BUYER'S USE THEREOF WILL BE SECURE OR UNINTERRUPTED, UNLESS OTHERWISE AUTHORIZED IN WRITING BY SELLER, THE SOFTWARE SHALL NOT BE USED IN CONNECTION WITH HAZARDOUS OR HIGH-RISK ACTIVITIES OR ENVIRONMENTS. EXCEPT AS EXPRESSLY STATED HEREIN, ALL PRODUCTS ARE PROVIDED "AS IS".

6. Claims; Commencement of Actions. Buyer shall promptly inspect all Products upon receipt. No claims for shortages will be allowed unless reported to Seller within ten (10) days of delivery. Buyer shall notify Seller of any alleged breach of warranty within thirty (30) days after the date the non-conformance is or should have been discovered by Buyer. Any claim or action against Seller based upon breach of contract or any other theory, including tort, negligence, or otherwise must be commenced within twelve (12) months from the date of the alleged breach or other alleged event, without regard to the date of discovery.

7. LIMITATION OF LIABILITY. IN THE EVENT OF A BREACH OF WARRANTY, SELLER WILL, AT ITS OPTION, REPAIR OR REPLACE THE NON-CONFORMING PRODUCTS, RE-PERFORM THE SERVICES, OR REFUND THE PURCHASE PRICE PAID WITHIN A REASONABLE PERIOD OF TIME. IN NO EVENT IS SELLER LIABLE FOR ANY SPECIAL, INDIRECT, INCIDENTAL OR CONSEQUENTIAL DAMAGES INCLUDING ANY LOSS OF REVENUE OR PROFITS, WHETHER BASED IN CONTRACT, TORT OR OTHER LEGAL THEORY. IN NO EVENT SHALL SELLER'S LIABILITY UNDER ANY CLAIM MADE BY BUYER EXCEED THE PURCHASE PRICE PAID FOR THE PRODUCTS.

8. Confidential Information. Buyer acknowledges and agrees that Confidential Information has been and will be received in confidence and will remain the property of Seller. Buyer further agrees that it will not use Seller's Confidential Information for any purpose other than for the benefit of Seller and shall return all such Confidential Information to Seller within thirty (30) days upon request.

9. Loss to Buyer's Property. Buyer's Property will be considered obsolete and may be destroyed by Seller after two (2) consecutive years have elapsed without Buyer ordering the Products manufactured using Buyer's Property. Also, Seller shall not be responsible for any loss or damage to Buyer's Property while it is in Seller's possession or control.

10. Special Tooling. Seller may impose a tooling charge for any Special Tooling. Special Tooling shall be and remain Seller's property. In no event will Buyer acquire any interest in the Special Tooling, even if such Special Tooling has been specially converted or adapted for manufacture of Goods for Buyer and notwithstanding any charges paid by Buyer. Unless otherwise agreed, Seller has the right to alter, discard or otherwise dispose of any Special Tooling or other property owned by Seller in its sole determination at any time.

11. Security Interest. To secure payment of all sums due from Buyer, Seller retains a security interest in all Products delivered to Buyer and, Buyer's acceptance of these Terms is deemed to be a Security Agreement under the Uniform Commercial Code. Buyer authorizes Seller as its attorney to execute and file on Buyer's behalf all documents Seller deems necessary to perfect Seller's security interest.

12. User Responsibility. Buyer, through its own analysis and testing, is solely responsible for making the final selection of the Products and assuring that all performance, endurance, maintenance, safety and warning requirements of the application of the Products are met. Buyer must analyze all aspects of the application and follow applicable industry standards, specifications, and any technical information provided with the Quote or the Products, such as Seller's instructions, guides and specifications. If Seller provides options of or for Products based upon data or specifications provided by Buyer, Buyer is responsible for

determining that such data and specifications are suitable and sufficient for all applications and reasonably foreseeable uses of the Products. In the event Buyer is not the end-user of the Products, Buyer will ensure such end-user complies with this paragraph.

13. Use of Products, Indemnity by Buyer. Buyer shall comply with all instructions, guides and specifications provided by Seller with the Quote or the Products. If Buyer uses or resells the Products in any way prohibited by Seller's instructions, guides or specifications, or Buyer otherwise fails to comply with Seller's instructions, guides and specifications, Buyer acknowledges that any such use, resale, or non-compliance is at Buyer's sole risk. Further, Buyer shall indemnify, defend, and hold Seller harmless from any losses, claims, liabilities, damages, lawsuits, judgments and costs (including attorney fees and defense costs), whether for personal injury, property damage, intellectual property infringement or any other claim, arising out of or in connection with: (a) improper selection, design, specification, application, or any misuse of Products; (b) any act or omission, negligent or otherwise, of Buyer; (c) Seller's use of Buyer's Property; (d) damage to the Products from an external cause, repair or attempted repair by anyone other than Seller, failure to follow instructions, guides and specifications provided by Seller, use with goods not provided by Seller, or opening, modifying, deconstructing, tampering with or repackaging the Products; or (e) Buyer's failure to comply with these Terms, including any legal or administrative proceedings, collection efforts, or other actions arising from or relating to such failure to comply. Seller shall not indemnify Buyer under any circumstance except as otherwise provided in these Terms.

14. Cancellations and Changes. Buyer may not cancel or modify, including but not limited to movement of delivery dates for the Products, any order for any reason except with Seller's written consent and upon terms that will indemnify, defend and hold Seller harmless against all direct, incidental and consequential loss or damage and any additional expense. Seller, at any time, may change features, specifications, designs and availability of Products.

15. Assignment. Buyer may not assign its rights or obligations without the prior written consent of Seller.

16. Force Majeure. Seller is not liable for delay or failure to perform any of its obligations by reason of any events or circumstances beyond its reasonable control. Such circumstances include without limitation: accidents, labor disputes or stoppages, government acts or orders, acts of nature, pandemics, epidemics, other widespread illness, or public health emergency, cyber related disruptions, cyber-attacks, ransomware sabotage, delays or failures in delivery from carriers or suppliers, shortages of materials, sudden increases in the price of raw material or components, shutdowns or slowdowns affecting the supply of raw materials or components, or the transportation thereof, oil shortages or oil price increases, energy crisis, energy or fuel interruption, war (whether declared or not) or the serious threat of same, riots, rebellions, acts of terrorism, embargoes, fire or any reason whether similar to the foregoing or otherwise. Seller will resume performance as soon as practicable after the event of force majeure has been removed. All delivery dates affected by an event of force majeure shall be tolled for the duration of such event of force majeure and rescheduled for mutually agreed dates as soon as practicable after the event of force majeure ceases to exist. The right to allocate capacity is in the Seller's sole discretion. An event of force majeure shall not include financial distress, insolvency, bankruptcy, or other similar conditions affecting one of the parties, affiliates and/or subcontractors. An event of force majeure in the meaning of these Terms means any circumstances beyond Seller's control that permanently or temporarily hinders performance, even where that circumstance was already foreseen. Buyer shall not be entitled to cancel any orders following its claim of an event of force majeure.

17. Waiver and Severability. Failure to enforce any provision of these Terms will not invalidate that provision; nor will any such failure prejudice either party's right to enforce that provision in the future. Invalidation of any provision of these Terms shall not

Continued on Next Page

Offer of Sale (Cont'd)

WARNING: This product can expose you to chemicals including Lead and Lead Compounds, and Di(2-ethylhexyl)phthalate (DEHP) which are known to the State of California to cause cancer and birth defects or other reproductive harm. For more information go to www.P65Warnings.ca.gov

invalidate any other provision herein and, the remaining provisions will remain in full force and effect.

18. Duration. Unless otherwise stated in the Quote, any agreement governed by or arising from these Terms shall: (a) be for an initial duration of one (1) year; and (b) shall automatically renew for successive one-year terms unless terminated by Buyer with at least 180-days written notice to Seller or if Seller terminates the agreement pursuant to Section 19 of these Terms.

19. Termination. Seller may, without liability to Buyer, terminate any agreement governed by or arising from these Terms for any reason and at any time by giving Buyer thirty (30) days prior written notice. Seller may immediately terminate, in writing, if Buyer: (a) breaches any provision of these Terms, (b) becomes or is deemed insolvent, (c) appoints or has appointed a trustee, receiver or custodian for all or any part of Buyer's property, (d) files a petition for relief in bankruptcy on its own behalf, or one is filed against Buyer by a third party, (e) makes an assignment for the benefit of creditors; or (f) dissolves its business or liquidates all or a majority of its assets.

20. Ownership of Rights. Buyer agrees that (a) Seller (and/or its affiliates) owns or is the valid licensee of Seller's IP and (b) the furnishing of information, related documents or other materials by Seller to Buyer does not grant or transfer any ownership interest or license in or to Seller's IP to Buyer, unless expressly agreed in writing. Without limiting the foregoing, Seller retains ownership of all Software supplied to Buyer. In no event shall Buyer obtain any greater right in and to the Software than a right in a license limited to the use thereof and subject to compliance with any other terms provided with the Software. Buyer further agrees that it will not, directly or through intermediaries, reverse engineer, decompile, or disassemble any Software (including firmware) comprising or contained within a Product, except and only to the extent that such activity may be expressly permitted, either by applicable law or, in the case of open-source software, the applicable open-source license.

21. Indemnity for Infringement of Intellectual Property Rights. Seller is not liable for infringement of any Intellectual Property Rights except as provided in this Section. Seller will defend at its expense and will pay the cost of any settlement or damages awarded in an action brought against Buyer based on a third-party claim that one or more of the Products infringes the Intellectual Property Rights of a third party in the country of delivery of the Products by Seller to Buyer. Seller's obligation to defend and indemnify Buyer is contingent on Buyer notifying Seller within ten (10) days after Buyer becomes aware of any such claim, and Seller having sole control over the defense of the claim including all negotiations for settlement or compromise. If one or more Products is subject to such a claim, Seller may, at its sole expense and option, procure for Buyer the right to continue using the Products, replace or modify the Products to render them non-infringing, or offer to accept return of the Products and refund the purchase price less a reasonable allowance for depreciation. Seller has no obligation or liability for any claim of infringement: (i) arising from information provided by Buyer (including Seller's use of Buyer's Property); or (ii) directed to any Products for which the designs are specified in whole or part by Buyer; or (iii) resulting from the modification, combination or use in a system of any Products. The foregoing provisions of this Section constitute Seller's sole and exclusive liability and Buyer's sole and exclusive remedy for claims of infringement of Intellectual Property Rights.

22. Governing Law. These Terms, the terms of any Quote, and the sale and delivery of all Products are deemed to have taken place in, and shall be governed and construed in accordance with, the laws of the State of Ohio, as applicable to contracts executed and wholly performed therein and without regard to conflicts of laws principles. Buyer irrevocably agrees and consents to the exclusive jurisdiction and venue of the courts of Cuyahoga County, Ohio with respect to any dispute, controversy or claim arising out of or relating to the sale and delivery of the Products.

23. Entire Agreement. These Terms, along with the terms set forth in the Quote, forms the entire agreement between the Buyer and Seller and constitutes the final, complete and exclusive expression of the terms of sale and purchase. In the event of a conflict between any term set forth in the Quote and these Terms, the terms set forth in the Quote shall prevail. All prior or contemporaneous written or oral agreements or negotiations with respect to the subject matter shall have no effect. No modification to these Terms will be binding on Seller unless agreed to in a writing that is signed by an authorized representative of Seller, excluding email correspondence, 'clickwrap' or other purported electronic assent to different or additional terms. Sections 2-25 of these Terms shall survive termination or cancellation of any agreement governed by or arising from these Terms.

24. No 'Wrap' Agreements/No Authority to Bind. Seller's clicking any buttons or any similar action, such as clicking "I Agree" or "Confirm," to utilize Buyer's software or webpage for the placement of orders, is NOT an agreement to Buyer's Terms and Conditions. **NO EMPLOYEE, AGENT OR REPRESENTATIVE OF SELLER HAS THE AUTHORITY TO BIND SELLER BY THE ACT OF CLICKING ANY BUTTON OR SIMILAR ACTION ON BUYER'S WEBSITE OR PORTAL.**

25. Compliance with Laws. Buyer agrees to comply with all applicable laws, regulations, and industry and professional standards, including those of the United States of America, and the country or countries in which Buyer may operate, including without limitation the U.S. Foreign Corrupt Practices Act ("FCPA"), the U.S. Anti-Kickback Act ("Anti-Kickback Act"), U.S. and E.U. export control and sanctions laws ("Export Laws"), the U.S. Food Drug and Cosmetic Act ("FDCA"), and the rules and regulations promulgated by the U.S. Food and Drug Administration ("FDA"), each as currently amended. Buyer agrees to indemnify, defend, and hold harmless Seller from the consequences of any violation of such laws, regulations and standards by Buyer, its employees or agents. Buyer represents that it is familiar with all applicable provisions of the FCPA, the Anti-Kickback Act, Export Laws, the FDCA and the FDA and certifies that Buyer will adhere to the requirements thereof and not take any action that would make Seller violate such requirements. Buyer represents and agrees that Buyer will not make any payment or give anything of value, directly or indirectly, to any governmental official, foreign political party or official thereof, candidate for foreign political office, or commercial entity or person, for any improper purpose, including the purpose of influencing such person to purchase Products or otherwise benefit the business of Seller. Buyer further represents and agrees that it will not receive, use, service, transfer or ship any Products from Seller in a manner or for a purpose that violates Export Laws or would cause Seller to be in violation of Export Laws. Buyer agrees to promptly and reliably provide Seller all requested information or documents, including end-user statements and other written assurances, concerning Buyer's ongoing compliance with Export Law.

09/22

Parker Worldwide

Europe, Middle East, Africa

AE – United Arab Emirates,
Dubai

Tel: +971 4 8127100
parker.me@parker.com

AT – Austria, Wiener Neustadt

Tel: +43 (0)2622 23501-0
parker.austria@parker.com

AT – Eastern Europe, Wiener
Neustadt

Tel: +43 (0)2622 23501 900
parker.easteurope@parker.com

AZ – Azerbaijan, Baku

Tel: +994 50 22 33 458
parker.azerbaijan@parker.com

BE/LU – Belgium, Nivelles

Tel: +32 (0)67 280 900
parker.belgium@parker.com

BG – Bulgaria, Sofia

Tel: +359 2 980 1344
parker.bulgaria@parker.com

BY – Belarus, Minsk

Tel: +375 17 209 9399
parker.belarus@parker.com

CH – Switzerland, Etoy

Tel: +41 (0)21 821 87 00
parker.switzerland@parker.com

CZ – Czech Republic, Klecany

Tel: +420 284 083 111
parker.czechrepublic@parker.com

DE – Germany, Kaarst

Tel: +49 (0)2131 4016 0
parker.germany@parker.com

DK – Denmark, Ballerup

Tel: +45 43 56 04 00
parker.denmark@parker.com

ES – Spain, Madrid

Tel: +34 902 330 001
parker.spain@parker.com

FI – Finland, Vantaa

Tel: +358 (0)20 753 2500
parker.finland@parker.com

FR – France, Contamine s/Arve

Tel: +33 (0)4 50 25 80 25
parker.france@parker.com

GR – Greece, Athens

Tel: +30 210 933 6450
parker.greece@parker.com

HU – Hungary, Budaoers

Tel: +36 23 885 470
parker.hungary@parker.com

IE – Ireland, Dublin

Tel: +353 (0)1 466 6370
parker.ireland@parker.com

IT – Italy, Corisico (MI)

Tel: +39 02 45 19 21
parker.italy@parker.com

KZ – Kazakhstan, Almaty

Tel: +7 7273 561 000
parker.easteurope@parker.com

NL – The Netherlands, Oldenzaal

Tel: +31 (0)541 585 000
parker.nl@parker.com

NO – Norway, Asker

Tel: +47 66 75 34 00
parker.norway@parker.com

PL – Poland, Warsaw

Tel: +48 (0)22 573 24 00
parker.poland@parker.com

PT – Portugal, Leca de Palmeira

Tel: +351 22 999 7360
parker.portugal@parker.com

RO – Romania, Bucharest

Tel: +40 21 252 1382
parker.romania@parker.com

RU – Russia, Moscow

Tel: +7 495 645-2156
parker.russia@parker.com

SE – Sweden, Spånga

Tel: +46 (0)8 59 79 50 00
parker.sweden@parker.com

SK – Slovakia, Banská Bystrica

Tel: +421 484 162 252
parker.slovakia@parker.com

SL – Slovenia, Novo Mesto

Tel: +386 7 337 6650
parker.slovenia@parker.com

TR – Turkey, Istanbul

Tel: +90 216 4997081
parker.turkey@parker.com

UA – Ukraine, Kiev

Tel: +380 44 494 2731
parker.ukraine@parker.com

UK – United Kingdom, Warwick

Tel: +44 (0)1926 317 878
parker.uk@parker.com

ZA – South Africa, Kempton Park

Tel: +27 (0)11 961 0700
parker.southafrica@parker.com

North America

CA – Canada, Milton, Ontario

Tel: +1 905 693 3000

MX – Mexico, Toluca

Tel: +52 72 2275 4200

Asia Pacific

AU – Australia, Castle Hill

Tel: +61 (0)2-9634 7777

CN – China, Shanghai

Tel: +86 21 2899 5000

HK – Hong Kong

Tel: +852 2428 8008

IN – India, Mumbai

Tel: +91 22 6513 7081-85

JP – Japan, Fujisawa

Tel: +81 (0)4 6635 3050

KR – South Korea, Seoul

Tel: +82 2 559 0400

MY – Malaysia, Shah Alam

Tel: +60 3 7849 0800

NZ – New Zealand, Mt Wellington

Tel: +64 9 574 1744

SG – Singapore

Tel: +65 6887 6300

TH – Thailand, Bangkok

Tel: +662 717 8140

TW – Taiwan, New Taipei City

Tel: +886 2 2298 8987

South America

AR – Argentina, Buenos Aires

Tel: +54 3327 44 4129

BR – Brazil, Cachoeirinha RS

Tel: +55 51 3470 9144

CL – Chile, Santiago

Tel: +56 2 623 1216

Pan Am, Miami

Tel: +1 305-470-8800

Parker-Hannifin Corporation

Chelsea Products Division
8225 Hacks Cross Rd
Olive Branch, MS 38654
United States

Phone: +1 (662) 895-1011

Email: chd_support@support.parker.com

www.Parker.com/Chelsea

PN: HY25-1238D-M1/US

Rev: 04/25

